

BRICK (VL-3004)

Unshielded bracket lights for LED PCB type & LED lamps (E-14)

Beam angle	Symmetrical
Luminous flux [lm]	540[lm] - 1,020[lm]
Protection Class	IP65
Certification	KS C 7713 (LED 경관등)



Description

모던한 디자인의 BRICK은 벽돌을 형상화하여 주변환경과 조화를 고려하여 디자인한 제품이며 온오프 부드러운 빛 연출이 가능하며, 유백색의 유리를 통해 발산되는 빛이 안락한 느낌을 가져다 주는 제품이다. 또한 현대적 감각의 간접조명과 고른 배광분포가 요구되는 아파트 입구, 문주 등의 적용에 적당한 BRICK은 전원공급 장치가 내장되어 편리하게 설치 및 유지보수가 가능하다.

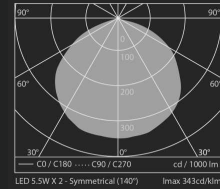

Energy Saving
45%
LED bulb 5.5W x 2 vs EL 20W

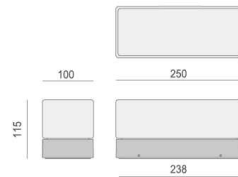

MODEL	CODE NO.	LAMP	BASE	INPUT	lm/cd
BRICK (브릭)	3004-L11	LED BULB 5.5W X 2	E-14	AC 220V	540[lm]
	3004-P12	LED 12W	PCB	AC 220V	1,020[lm]

- Materials :** Body_ aluminum die casting. Diffuser_ 3mm toughened milky glass. Cover frame_ aluminum die casting. Attach bracket_ steel plate(direct current electroplating). Gasket and seals_ silicone rubber. Fixings_ stainless steel screws.
- Vents :** Waterproof protective lamp vent (IP67)
- Finishing :** Mechanical and chemical anti-corrosion treatment; AKZONOBEL, Polyester, UV resistant, exterior paint system, thermally cured at 200 °C
- Adjustment :** Fixed lighting fixture
- Paint Color :** Gray painted (Standard) / Another paint color on request
- Power :** Electronic power supply unite included
- Input Voltage :** AC 220~240V 60Hz
- Option :** Cable lengths on request

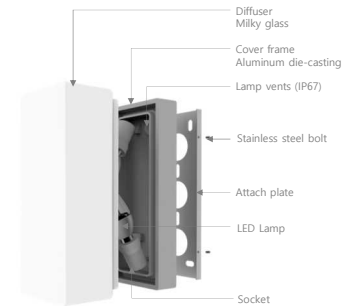

_ BRICK BRACKET LIGHT EXPLODED VIEW